



# The ARA Show Rules and Regulations

Las Vegas Convention Center  
Exhibits: Jan. 30- Feb. 1, 2025

These Rules and Regulations are an integral part of the Exhibit Space Application/Contract (the "Exhibit Space Contract") submitted to the American Rental Association ("ARA") by Exhibitor. The purpose of these rules is to assure that all exhibitors are given equal opportunity to conduct business in a safe, attractive, professional exposition. Exhibitor is responsible for reading and understanding all Rules and Regulations.

Failure to comply with these Rules and Regulations may result in the loss of priority points, the removal of Exhibitor's exhibit and/or its agents or employees from The ARA Show, the exclusion from future trade shows and/or other discipline determined by ARA in its sole discretion. Exhibitor agrees that it and its employees and agents will abide by these Rules and Regulations and any additions and/or amendments which ARA may put into effect. ARA shall have the final authority to interpret and enforce these rules. All matters not covered by these Rules and Regulations are subject to the decision of ARA. All decisions so made shall be as binding on all parties. All questions, problems and disputes must be directed to ARA.

In addition, the Exhibitor assumes all responsibility for any compliance with all pertinent ordinances, regulations and codes of duly authorized local, state and federal governing bodies concerning fire, safety and health, together with the rules and regulations of the operators and/or owners of the property wherein the show is held.

**1. Payment and Cancellation Policies.** Prior to September 9, 2024, a deposit of 30 percent of the total cost of the booth space must accompany Exhibitor's signed Exhibit Space Contract. On or after September 23, 2024, full payment of booth space is required. If Exhibitor fails to meet this payment schedule or has any other past due account with ARA, then ARA may, at its option and without penalty, terminate the Exhibit Space Contract.

Exhibitor may cancel all or part of its booth space by written notice to ARA. Booth space will be considered canceled by Exhibitor upon the date that written notice of cancellation is received by ARA. Exhibitor may cancel booth space (in whole or in part) on or before September 9, 2024, without cost and ARA will refund all deposits and other amounts paid by Exhibitor with respect to such canceled booth space. Exhibitor may cancel booth space (in whole or in part) after September 9, 2024, but before October 14, 2024, but will be assessed an administrative fee of 30 percent of the cost of such canceled booth space and ARA will refund all deposits and other amounts paid by Exhibitor with respect to such canceled booth space in excess of such fee. No refunds will be made with respect to canceled booth space (in whole or in part) if notice of cancellation is received after October 14, 2024; provided, however, if Exhibitor fails to notify ARA that it will not be utilizing its booth space prior to the show dates (i.e., Exhibitor is a "no show"), Exhibitor shall be subject to discipline by ARA. If Exhibitor partially cancels its booth space following initial space assignment, ARA reserves the right to relocate Exhibitor's exhibit space to meet the needs of The ARA Show.

**2. Space Assignment.** All standard display booths are 10-ft. by 10-ft. (100 sq. ft. minimum). Dimensions of all booths shown on the exhibit diagram are believed to be accurate but are only warranted to be approximate. ARA reserves the right to make such modifications as may be necessary to adjust the floor plan to meet the needs of The ARA Show and exhibitors. Exhibit space is allocated according to the space assignment policies; provided, however, that ARA may, in its sole discretion, limit the number of booths that any one exhibitor may purchase. ARA reserves the right to allocate a percentage of floor space to accommodate new exhibiting companies.

Exhibitor shall not assign, sublet or share the space allotted. Names other than that of Exhibitor may not be displayed without prior approval.

Beginning in late June or early July, exhibit space will be assigned according to the following priority point system:

Five points	Associate Membership
Three points	Each year exhibited
Two points	Each 10-ft. by 10-ft. booth (100 sq. ft.) assigned
Two points	Paid display advertising in <i>The 2024 ARA Show Directory</i>
Five points	Platinum Level Sponsorship – The ARA Show 2024
Two points	Gold Level Sponsorship – The ARA Show 2024
One point	Silver Level Sponsorship – The ARA Show 2024

Following the initial booth assignment, space will be assigned on a first-come, first-served basis.

ARA will attempt to accommodate requests from companies that want to be located near or next to each other. However, the priority point system will not be compromised. If both companies consent to being assigned space based on the points of the company that has fewer points, there is a much greater chance of accommodating the request. ARA must receive this consent in writing prior to initial space assignment.

Companies that have merged with, been purchased by or have purchased another company may use the priority points from whichever company is most favorable, but may not combine the priority points of multiple companies; provided, however, that in order to transfer points from one company to another, the product lines being displayed must be similar and must be marketed under the same or similar name for at least one year. Where only certain assets of a company are transferred to another, ARA will consider transfer requests considering all of the facts and circumstances.

All requests for priority point transactions shall be submitted in writing to ARA. Exhibitors have no contractual, ownership or other property rights in priority points, and ARA shall have the power, in its sole discretion, to interpret and/or modify this policy.

If a company does not exhibit for a period of three years, points for number of years exhibiting will revert to zero.

**3. Installation and Dismantling of Exhibits.** No children under the age of 16 will be allowed in the exhibit hall or on the docks during installation or dismantle of exhibits.

**Move-In Schedule (tentative)**

Saturday, January 25, 2025... 8 a.m. – 5 p.m.  
Sunday, January 26, 2025... 8 a.m. – 5 p.m.  
Monday, January 27, 2025... 8 a.m. – 5 p.m.  
Tuesday, January 28, 2025... 8 a.m. – 5 p.m.  
Wednesday, January 29, 2025... 8 a.m. – 5 p.m.

All exhibits will be installed during the hours designated by ARA and must be erected and completely arranged by 5 p.m. on Wednesday, January 29, 2025. If an Exhibitor fails to occupy the assigned space by this deadline, ARA has the right to utilize the area in any way it may decide without relieving Exhibitor of the obligation to pay in full and will authorize, at Exhibitor's expense, the removal to storage of any booth materials not set by the specified time.

ARA will conduct an exhibit hall inspection during move-in; any violations will be noted, and Exhibitor will be required to correct any violation(s) prior to show opening. Refusal or failure may result in ARA correcting said violation(s) at Exhibitor's expense, or possible eviction from The ARA Show. Move-in or setup of exhibits during show hours will not be permitted.

**Trade Show Dates (tentative)**

Thursday, January 30, 2025... 9:30 a.m. – 5 p.m.  
Friday, January 31, 2025... 9 a.m. – 5 p.m.  
Saturday, February 1, 2025... 9 a.m. – 1 p.m.

**Move-Out Schedule (tentative)**

Saturday, February 1, 2025... 1 p.m. – 9 p.m.  
Sunday, February 2, 2025... 8 a.m. – 5 p.m.  
Monday, February 3, 2025... 8 a.m. – 5 p.m.

Exhibitors will not be allowed to dismantle or repack any part of their exhibits until after the official closing of The ARA Show. Noncompliance will result in a written warning with points suspended for that year (no points earned); a second-year violation will result in the complete loss of Exhibitor's priority points; a third-year violation will result in Exhibitor being barred from exhibiting in The ARA Show for an amount of time to be determined by ARA. Products on display or other items awarded as prizes or given away are not allowed to be carried out of the exhibit area until after the official closing of The ARA Show. Exhibit material other than hand-carried material cannot be removed from the booth until the aisle carpeting is removed. Exhibitors having exhibit material removed through the freight doors after the close of The ARA Show by persons other than Exhibitor's badged employees must place this information on file at the freight service desk and instruct those persons to report to that desk for access to The ARA Show floor. Any exceptions must have the approval of ARA.

**4. Standard Booth Equipment.** Included in the price of each booth (except islands) will be 8-ft. high draped background with 3-ft. high draped sidewalls and a 7-in. by 44-in. company identification sign listing company name, city, state and booth number. ARA will be responsible for aisle carpeting and general exhibit hall overhead lighting.

All other services required such as material handling, booth carpet, furnishings, electricity, telephone, Internet, etc., must be arranged through the official decorator, Convention Center or other official suppliers designated by ARA. Exhibitor and its employee and agents must comply with all local ordinances, codes and union jurisdictions.

ARA will include Exhibitor's name, address, phone, fax, website, product description, booth number and product categories in the official Show Directory. This information is to be supplied by Exhibitor on this Exhibit Space Contract, and ARA will not be responsible for any errors or omissions.

**5. Space Regulations.** ARA reserves the right to restrict, prohibit or evict exhibits, which, because of noise, method of operation, materials, creation of safety hazards or any other reason, detract from the general character of The ARA Show as a whole. In addition:

**Size.** All exhibit booths will be 10-ft. by 10-ft. minimum. Islands and peninsulas must be 20-ft. by 20. ft minimum. The following booth sizes cannot be accommodated: 30-ft. by 30-ft., 30-ft. by 40-ft, and 40-ft. by 40-ft. These booth sizes disrupt the traffic flow on the trade show floor, to the detriment of the attendees. The maximum amount of space that can be requested is 5,000 sq. ft. The maximum number of booths allotted to one company is six booths.

**Location.** All exhibits will be located in the Las Vegas Convention Center and designated exhibit areas. Exhibits may not be located (a) outside the exhibit floor of the Convention Center and designated exhibit areas, (b) in parking areas or venues in or surrounding the Convention Center or (c) in ARA participating or non-participating hotels.

**Eligibility.** Only products and/or services that are marketed to the rental equipment industry are eligible for display. Refurbished equipment is allowed to be displayed in the booth at the discretion of ARA with the following stipulations: (a) the equipment looks like new; (b) the equipment is an original product or service of the exhibiting manufacturer; and (c) the equipment must be identified as being remanufactured.

**Marketing Activities.** All demonstrations or other promotional activities must be confined within the limits of the exhibit booth. Demonstrations or activities that cause annoyance to neighboring exhibitors such as flashing lights or noise or result in obstruction of aisles or prevent ready access to a nearby exhibitor's booth will not be allowed. Exhibitors shall distribute printed matter, promotional items or other articles only within the confines of the exhibit space. Musicians and singers are prohibited. Models or other entertainers will not be permitted to wear attire other than that which conforms to normal business or daytime social standards. ARA reserves the right of approval of said models and their attire, as well as the attire of other booth personnel.

**Fundraising Activities.** Fundraising activities of any kind are not permitted at The ARA Show.

**Press Conferences.** All press conferences must be scheduled through The ARA Show. Please go to the show website ([www.ARAshow.org](http://www.ARAshow.org)) for details. Companies that book press conferences outside of the official schedule will be subject to loss of priority points for the upcoming year.

**Noise.** Exhibitors must take every reasonable precaution to minimize the noise of demonstrations or of operating exhibits. In the event that any other Exhibitor complains or protests to the noise level, ARA reserves the right to require Exhibitor to cease operation of the exhibit or take measures to reduce the noise level (under 85 decibels).

**Balloons.** Balloons may not be exhibited or displayed unless manufactured and distributed in the normal course of business by the exhibiting firm. If inflated and displayed, balloons must be displayed within the limitations of the Rules and Regulations. Inflated balloons must be inflated only with air or heavier-than-air gas; helium is not permitted.

**Safety.** ARA reserves the right to require equipment be repositioned and the right to stop any product demonstration on The ARA Show floor which is determined to be a hazard, a disruption of The ARA Show or not consistent with the Rules and Regulations.

**Vehicles.** Operation of gasoline-operated vehicles/equipment will be permitted during move-in and move-out periods. Vehicles/equipment of any type on display that are powered by fuel can have no more than ¼ tank of gas in the fuel tank (or amount designated by the Convention Center and local fire ordinances), and that fuel tank must be sealed with either a locking fuel cap or by tape. Batteries must be disconnected. External chargers are usually recommended for demonstration purposes. Propane tanks are not allowed, even if empty.

**Inflatables.** Inflatables must be displayed within the limitations of the Rules and Regulations and, for safety reasons, inflatable slides, bouncers, jumpers, obstacle courses, and the like may not be used or demonstrated (either by exhibitor personnel or attendees). *Exhibitors displaying inflatables must provide ARA a copy of their certificate of liability insurance (see #12).*

**Booth Canopies and Ceilings, Enclosed Areas.**

Coverings must be made of non-combustible materials and a certificate of treated materials must be presented upon request. Covered areas 400 sq. ft. or larger must be furnished with an acceptable battery-powered smoke detector which emit alarms audible outside of the enclosed or covered area. The sides of the booth must be open or have means of egress on three of the four sides. Each covered area must be supplied with a class 2A10BC fire extinguisher positioned in a visible location and accessible at all times. Booth personnel must be familiar in the use of extinguishers.

**Food and Beverage Dispensing.** Exhibitor may not dispense food and/or beverages of any kind without written permission from the exclusive Convention Center caterer. The serving and associated charges of food or beverage in display booths is the responsibility of Exhibitor. Serving of alcoholic

beverages from Exhibitors' booth is prohibited at any time during the trade show or during the installation and dismantling of exhibits.

**6. Construction and Arrangement Limitations.** All exhibits must conform to the International Association of Exhibitions and Events display guidelines adopted by ARA and distributed with booth assignments (in Exhibitor Service Kit, viewable online through Exhibitor Resources on [www.ARAshow.org](http://www.ARAshow.org) or sent upon request) and all rules and regulations of the Convention Center.

All materials used in display construction or decorating will be made of fire-retardant materials and be certified as flame retardant. Samples should be available for testing. Materials that cannot be treated to meet the requirements should not be used. A flame-proofing certificate must be available for inspection. Exhibitor is responsible for compliance with all life/safety and fire codes.

Signs and lighting truss may be suspended from the ceiling in either island or peninsula locations. All items suspended from the ceiling must comply with facility requirements and must be professionally produced. Signage must not violate The ARA Show's 20-ft. height restrictions. The suspended height is 20 ft. when measured from the floor up to the top of the sign. No signage shall be displayed on exhibits and/or products at a height that exceeds the height regulations of the exhibitor's booth except that the name, trademark and insignia used on a product as sold may be carried on the product exhibited.

Height limitations do not apply to equipment manufactured in the normal course of business by Exhibitor and displayed in its normal operating position. However, such equipment must remain completely within the confines of the exhibit space.

ARA reserves the right to have any finishing done to any exhibit that does not lend itself to an attractive appearance, such as unfinished sides or end panels. Such expense incurred will be at Exhibitor's expense.

Bridging of floor surfaces or roof structures across aisles is not allowed.

**7. Drayage and Shipping.** Freeman, the official general service contractor, will control the unloading and loading of all vehicles at the loading docks. The Exhibitor Service Manual will contain information on where to ship all goods and display materials being shipped to the show.

The official general service contractor will receive all crated shipments up to 30 days in advance and deliver them to the booths for installation, remove empty crates from the exhibit area before show time and return same to exhibit booths upon the close of The ARA Show. Shipments will be accepted at the show site based on targeted freight delivery schedule. Information and material handling charges for warehouse and show site shipments will be included in the Exhibitor Service Manual.

Full-time Exhibitor personnel shall have the right to unload POV's (privately-owned vehicles); POV's are limited to cars, pick-up trucks, vans and other vehicles primarily designated for passenger use, not cargo or freight, and limited to a maximum 30 minutes of dock time. No material handling equipment may be used, nor will it be loaned to Exhibitor.

Two-wheeled airplane luggage-type dollies or the equivalent are allowed. Materials being unloaded must not exceed a total of 300lbs. Please see details in the Exhibitor Service Manual for complete POV procedures.

Empty crates must be stored in a location that is acceptable to the local fire marshal and the official general service contractor, and will not be permitted to remain in the exhibition area and building during the course of The ARA Show.

**8. Americans with Disabilities Act.** Exhibitor represents and warrants that its exhibit and product/service information shall comply with the Americans with Disabilities Act, its regulations and guidelines (collectively "ADA"). Exhibitor shall indemnify, defend and hold harmless the American Rental Association, its directors, officers, employees and agents, and each of them, from and against any and all claims and expenses, including attorney's fees and costs, arising out of or related to Exhibitor's breach of this provision or noncompliance with any provision of the ADA.

**9. Intellectual Property Rights.** No visual or audio recording or transmission of the exhibition shall be made without the prior consent of ARA.

Exhibitor represents and warrants that it is (a) the lawful owner or licensee of any trademarks, trade names, service marks or domain names used in any displays, advertisements, printed material or other matter during the course of or otherwise related to The ARA Show and that the use of any intellectual property at The ARA Show does not infringe on the rights of any other party and (b) the lawful holder or licensee of any patent, trademark, copyright or other intellectual property right in any product, device or printed matter used, displayed or distributed by Exhibitor during the course of or otherwise related to The ARA Show. Exhibitor acknowledges and agrees that it shall be solely responsible for obtaining any licenses, permits, etc., which may be required for it to broadcast, perform or display any copyrighted materials including, but not limited to, music, video and software. Exhibitor shall indemnify, defend and hold harmless the American Rental Association, its directors, officers, employees and agents, and each of them, from and against any and all claims and expenses, including attorney's fees and costs, arising out of or related to Exhibitor's breach of this provision.

ARA cannot and will not intervene in any legal disputes between exhibitors. ARA will cooperate with the enforcement (but will not itself enforce) of valid court orders; provided, however, that Exhibitor agrees to comply with the following in connection with the enforcement of any court order: (a) all court orders must be presented to Show Management prior to serving any exhibitor with such order; (b) all court orders shall be served other than during regular show hours; and (c) every effort will be made by Exhibitor to avoid disrupting The ARA Show in connection with the enforcement of any court order.

If Exhibitor is determined by a court of competent jurisdiction to have violated the representations, warranties or agreements set forth in this Section, ARA reserves the right to discipline Exhibitor. Such discipline may include loss of priority points, removal of an exhibit during The ARA Show and/or a temporary or permanent ban from exhibiting at The ARA Show. If Exhibitor believes that another exhibitor has

violated the provisions of this Section 9, Exhibitor should contact the Associate Member Director.

**10. Care of Building and Equipment.** Exhibitor is directly responsible for any damage to the Convention Center. Nothing may be affixed to any wall, ceiling or floor without express written permission from the Convention Center. Exhibitor, or its agents, must not injure or deface the walls or floors of the building, the booths or the equipment of the booths. No nails or tacks may be driven in building walls, floors or columns, and equipment must be self-supporting. Exhibitor shall indemnify, defend and hold ARA harmless for all claims for damage to exhibit space and exhibit premises caused or contributed to by its employees, agents and guests.

**11. Security.** ARA will provide perimeter security in the exhibit hall 24 hours a day, including move-in, show and move-out days. Exhibitor is responsible for the security and protection of its displays and other property at all times and is urged to take whatever precautions necessary to protect its property, including insurance as well as special guards. ARA, the Convention Center and the official general service contractor shall not be liable for any loss, damage or displacement of Exhibitor's property due to any cause.

**12. Liability and Insurance.** Neither ARA, the Convention Center, their officers, directors, employees, representatives, nor agents will be responsible for any loss, damage or injury that may occur to Exhibitor, Exhibitor's employees or Exhibitor's property from any cause whatsoever. All property of an Exhibitor is understood to remain in its own care, custody and control in transit to, from or within the confines of the exhibit hall.

Exhibitor shall indemnify, defend and hold harmless ARA, the Convention Center, their respective officers, directors, employees and agents from and against any and all losses, costs, damages, liability, or expenses (including attorneys fees) arising from or by reason of any accident, bodily injury, property damage or other claims or occurrences to any person, including Exhibitor, its employees and agents, or any business invitees, arising from or related to (a) violation of any law or ordinance by Exhibitor, its employees or its agents, (b) violation of this Contract for Exhibit Space by Exhibitor, its employees or its agents, or (c) Exhibitor's occupancy or use of the exhibition premises in the Convention Center or in and adjacent to the Convention Center, including storage and parking areas. The terms of this provision shall survive the termination or expiration of this Contract for Exhibit Space.

Exhibitor agrees to maintain U.S. liability insurance in an amount not less than one million dollars (\$1,000,000) to cover its potential liabilities under this Contract for Exhibit Space and to name ARA, the official show contractor, and the convention center as an additional insured under the policy or policies for the period of The ARA Show including move-in and move-out periods. Exhibitor shall provide ARA a certificate of insurance upon request. Exhibitor's failure to maintain the proper insurance to cover its liabilities shall constitute a material breach to this Contract for Exhibit Space.

**13. Badge Registration.** Exhibit hall attendance is restricted to qualified exhibitors, attendees and service suppliers as monitored by ARA. Badges are required at all times.

Exhibitor is limited to the number of complimentary exhibitor badges based on the size of contracted exhibit space. Use of an exhibitor badge by anyone other than the person named thereon is expressly prohibited. Any violations may result in the automatic removal of the exhibitor badge and will be considered just cause to expel Exhibitor and its representatives from The ARA Show floor and/or invoice the exhibiting company for the full registration fee as a result of false certification. Exhibitors witnessing such violation are urged to report said violation to ARA.

Firms or organizations (non-exhibiting suppliers) not assigned exhibit space will not be permitted to solicit business within the exhibit area and areas outlined above. Any company found to be conducting business as outlined in the manner will be in violation and removed from the exhibit hall.

**14. Exhibitor-Sponsored Functions.** Exhibitor may not schedule functions such as hospitality suites, field trips, tours, meetings, receptions, etc., to which attendees are invited during The ARA Show hours nor during any official function of The ARA Show.

**15. Cancellation.** In case of cancellation of The ARA Show by ARA or as a result of the unavailability of the exhibit space for any reason, including: due to war, threats or acts of terrorism, governmental action or order, act of God, fire, strike, labor disputes or any other causes beyond ARA's reasonable control, this Exhibit Space Contract shall terminate, and Exhibitor shall be entitled to the return of the rental fee for the exhibit space, less the pro rata share (based on exhibit space) of the expenses incurred by ARA in

connection with The ARA Show. ARA's maximum liability to Exhibitor with respect to the cancellation of The ARA Show shall not exceed in any circumstances or under any legal theory the return of sums paid by Exhibitor to ARA for the exhibit space.

**16. Additional Rules and Regulations.** In addition to the terms and conditions of this Contract for Exhibit Space, Exhibitor shall observe and abide by any additional rules or regulations of ARA and/or the Convention Center in effect from time to time.

**17. Miscellaneous.** This Contract for Exhibit Space is the sole and exclusive binding agreement between the parties hereto, shall supersede all other written or oral agreements between the parties with respect to the subject matter hereof and may not be modified or amended except by a writing signed by both parties. This Agreement shall in all respects be governed by the internal laws of the state of Illinois, without regard to principles of conflicts of laws. Any action or proceeding arising out of or related to this Contract for Exhibit Space shall be brought exclusively in the courts of the State of Illinois, County of Rock Island, or, if it has or can acquire jurisdiction, in the United States District Court for the Central District of Illinois, and each of the parties consents to the jurisdiction of such courts (and of the appropriate appellate courts) in any such action or proceeding and waives any objection to venue laid therein. Process in any action or proceeding referred to in the preceding sentence may be served on either party anywhere in the world.



# Exhibit Construction Guidelines

These rules have been adopted to give each exhibitor more effective use of his space without infringing on the rights of neighboring booths.

Space dimensions shown on floor plans are from center line of booth equipment, such as side rails and/or back drape. Exhibit structures must be constructed to allow sufficient tolerance on each side for this equipment and for utility service at rear of booth.

Definitions:

**Equipment** refers to products regularly manufactured and/or offered for sale by the exhibitor. Height limitations do not apply to equipment displayed in its normal operating position.

**Display Material** refers to any and all items used in an exhibitor's booth other than equipment. Display material includes, but is not limited to, signs, shelving, stands and other furniture, lighting fixtures, canopies, false ceilings, banner or flags.

**Height** is a critical dimension in the construction of exhibits. An objective of these guidelines is to ensure that every exhibitor has an equal opportunity to be seen. Specific height limitations for each type of booth and within each type of booth are indicated in the diagrams which follow. In general, greater heights are permitted in portions of booths farthest removed from adjoining booths. Lower height limitations prevail where they are necessary to ensure sight lines from the aisles of adjoining booths.

## STANDARD (IN-LINE) BOOTH

Definition: One or more standard units in a straight line (minimum booth size is 10 ft. by 10 ft.) It is enclosed on three sides by a back wall and two side walls, except for a corner booth, which may be open on the side facing the cross aisle as well as the front. A standard in-line booth backs up to other booths in the next row.

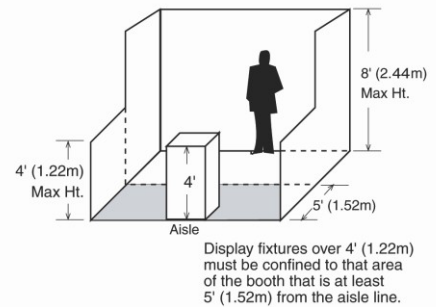

## USE OF SPACE

### Height

- The maximum height for display materials is 8 ft.
- There are no hanging signs permitted in linear booths.

Intent: If a portion of an exhibit booth extends above 8 ft. high, the exhibit booth background will detract from the overall impact of the exhibit directly behind that booth regardless of how the rear of the offending exhibit is finished.

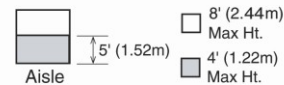

### Depth

- All display fixtures over 4 ft. in height and placed within 10 lineal ft. of an adjoining exhibit, must be confined to that area of the exhibitor's space which is at least 5 ft. from the aisle line.
- When three or more booths (10 ft. by 30 ft. or greater) are used in combination as a single exhibit space, the 4-ft. height limitation is applied only to that portion of the space that is within 10 lineal ft. of an adjacent booth.

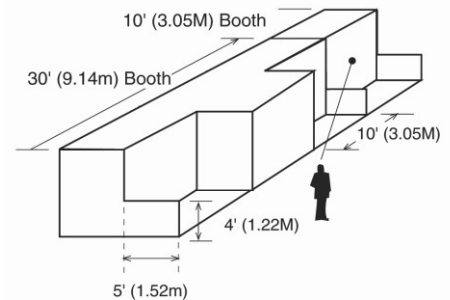

Intent: Each exhibitor is entitled to a reasonable sight line from the aisle regardless of the size of exhibit. Exhibitors with larger space – 30 lineal ft. or more – should also be able to effectively use as much of the total floor space as possible as long as they do not interfere with the rights of others. The limitation on display fixtures over 4 ft. and within 10 lineal ft. of a neighboring exhibit is intended to accomplish both aims.

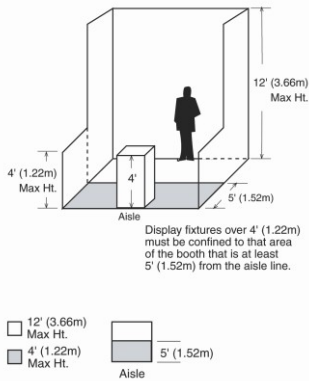

### PERIMETER WALL BOOTH

Definition: Standard booth located on the outer wall or perimeter of the exhibit floor.

### USE OF SPACE

All guidelines for standard (in-line) booths apply to perimeter booths except that the maximum allowable back wall height is 12 ft.

Intent: Because the outer perimeter booths do not back up against another exhibitor's booth, display walls and materials will not interfere with or distract from any other exhibitor booth.

### PENINSULA BOOTH

Definition: A 20-ft. by 20-ft. or larger exhibit with aisles on three sides back-to-back with another exhibit of the same configuration or a row of standard booths.

### USE OF SPACE

- When a peninsula booth backs up to two standard (in-line) booths, the back wall is restricted to 4 ft. high within 5 ft. of each aisle, permitting adequate line of sight for the adjoining standard booths.
- Hanging signs must be set forward a minimum of 5 ft. from the back line of the booth and adjacent neighbor to not detract from the overall impact of the exhibit directly adjacent.
- 20 ft. is the maximum height allowance, including signage for the center portion of the back wall.
- Identification signs, whether they are part of the display, or hanging, must conform to height restrictions.
- Identification of any kind is not allowed on the back wall which adjoins another exhibitor. This includes company logos.

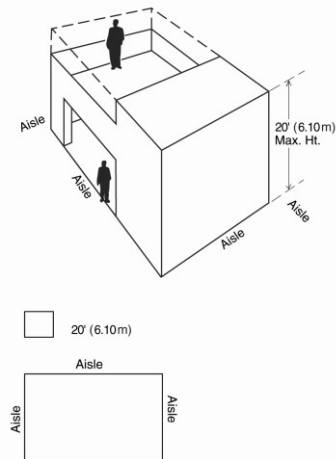
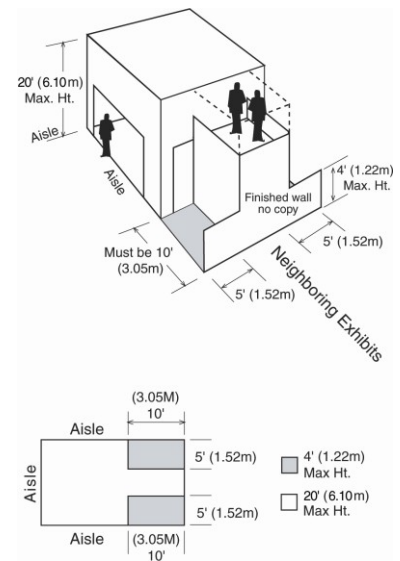

### ISLAND BOOTH

Definition: A 20-ft. x 20-ft. or larger freestanding exhibit with aisles on all four sides.

### USE OF SPACE

Exhibit fixtures, components and identification signs will be permitted to a maximum height of 20 ft.

Because an island booth is automatically separated by the width of an aisle from all neighboring exhibits, full use of the purchased space is permitted.

All fully enclosed booths with enclosed rooms must have at least two (2) exits leading directly to the aisle. These booths must possess a smoke detector and fire extinguisher for each enclosed area.

If any exhibiting booths have multiple levels or room(s) with enclosures, visible notification must appear on the stairway(s) or outside the room. This notice must state the maximum occupancy permissible or total weight load allowable on the second story at one time. If the second story occupancy level allows more than ten (10) people at one time, a second stairway must be present.

All multi-level booths must be stamped by a certified structural engineer and must have two (2) means of egress from upper levels.

All exhibit booths with solid covers and that exceed 1,000 sq. ft. in area are required to contain approved internal automatic fire sprinklers.

## CANOPIES AND CEILINGS

Canopies, including ceilings, umbrellas and canopy frames, can be either decorative or functional (such as to shade computer monitors from ambient light or for hanging products). Canopies for standard or perimeter booths should comply with the line of sight requirements (see "Use of Space" for standard or perimeter booths).

The base of the canopy should not be lower than 7 ft. from the floor within 5 ft. of any aisle. Canopy supports should be no wider than 3 in. This applies to any booth configuration that has a sightline restriction, such as a standard booth. Fire and safety regulations in many facilities strictly govern the use of canopies, ceilings and other similar coverings.

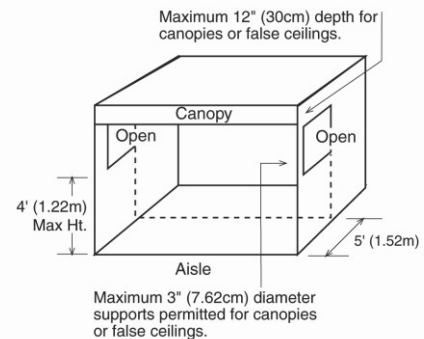

## HANGING SIGNS AND GRAPHICS

Because hanging objects involve safety, liability and good-neighbor issues, please read and understand the rules and make sure all your designers and production partners do so as well.

Intent:

- To accommodate exhibitors' use of overhead signage and lighting effects;
- To preserve potential sight lines for all exhibitors' displays and signs;
- To maintain an environment that allows for all exhibitors to conduct effective, uninterrupted business;
- To maintain public safety at all times.

Rules:

- Only island and peninsula exhibits may use overhead items.
- Hanging signs may not exceed the perimeter of assigned booth space.
- In peninsula booths, all hanging signs must be set forward a minimum of 5 ft. from the back line of the booth and adjacent neighbor to not detract from the overall impact of the exhibit directly adjacent.
- The suspended height is 20 ft. when measured from the floor up to the top of the sign.
- No overhead item can be allowed to harm the operation of neighboring exhibits.
- Drop wires can be conditionally permitted to help support exhibit attachments.
- All lighting and production contractors must meet ARA Exhibitor-Appointed Contractor (EAC) requirements.
- Exhibitors who use overhead signs and/or rigging are responsible for all costs and risks, including the risk that the items may not be satisfactorily visible when in place.
- Forms (Exhibitor Service Kit) for these services will be provided by Freeman.
- For shipping information (dates and location) refer to the Exhibitor Service Manual.



## OUTDOOR EXHIBITS (AS OF 4/3/2024)

- Outdoor exhibits that have tents, pavilions, trailers, or sprung structures must be on a 10-ft.-wide aisle and the floorplan must be approved by Clark County Building and Fire Prevention permitting. Please submit to [boothplans@lvcva.com](mailto:boothplans@lvcva.com).
- Open trash containers/boxes are required when parking lots are used for exhibits. If containers are ordered through the facility, lessee will incur trash removal charges.
- For any temporary assembly structures such as Multilevel and/or Covered Exhibits (Outdoor) submit floorplan for approval by Clark County Building and Fire Prevention permitting. Please submit to [boothplans@lvcva.com](mailto:boothplans@lvcva.com).
- All banner material used outside must be made of mesh material (a minimum of 30 percent pass through) or slatted to allow for air to flow through.
- Installation and dismantling of tower cranes require a 300-ft. clear zone. All tower cranes require FAA approval.
- If pouring a sub-floor made of concrete onto the asphalt, Visqueen must be used under the pour and the surrounding area. Bonding agents are prohibited.
- All other poured concrete requiring framework (curbing, walls, etc.) will use 16 penny nails with wire to mount and secure all batter board, bracing, etc., in asphalted areas. Square, round or other standard stakes are not permitted to secure framework in asphalted areas. Mechanical forms are preferred. Las Vegas Convention and Visitors Authority (LVCVA) exterior engineers are available for clarification.
- Any fuel storage greater than 10 gallons of gasoline or 60 gallons of combustible liquid (e.g., diesel) on property will require a Clark County Permit.
- Any exterior water use during shows will be metered. Please contact the Convention Services Manager (CSM) for coordination.
- ARA and LVCVA management reserves the right to make any changes on site that are deemed necessary without advance notice, for safety concerns.

## TENTS AND CANOPIES

- All outdoor tents and/or temporary structures must be installed by facility approved exhibitor appointed contractors (EAC's) and must submit and receive an approved staking plan before staking can occur. Staking plans should be submitted 30 days prior to [staking@lvcva.com](mailto:staking@lvcva.com).
- All tents (a structure that is covered with a soft top and soft sides) greater than 400 sq. ft. require a Clark County permit. They must also have a 2A40BC fire extinguisher that has a current Nevada state inspection tag.
- All canopies (covered with a soft top but no sides) greater than 700 sq. ft. require a Clark County permit. They must also have a 2A40BC fire extinguisher that has a current Nevada state inspection tag.
- Self-installed pop-up canopies requiring either weights or stakes must be lowered every evening at close of show and, depending on weather conditions, may need to be taken down; to be determined by facility on site.

## STAKING

- All staking needs to be drilled; no hand staking is permitted.
- Anchoring or staking into concrete is prohibited property wide.
- Trenching or digging is not allowed into the asphalt without the prior approval from a CSM; please contact [staking@lvcva.com](mailto:staking@lvcva.com) for approval.
- Final on-site staking approval must be obtained by the Engineering Department before any drilling and staking may begin.
- The asphalt must be returned to its original condition. LVCVA standards are:
  - Backfill existing hole(s) with clean, fine-type sand. Tamp to within four inches (4") minimum of grade surface.
  - Fill rest of hole(s) with Aquaphalt® or equivalent and tamp until solid.
  - Cover areas approximately two inches (2") around patched hole with a good grade of plastic-type asphalt sealer with a maximum drying time of two (2) hours.
  - West Hall – All staking will not exceed 40 in. in depth. If additional anchoring is necessary, weights will be required.

## TRUSS STRUCTURES

- All truss structures require plans to be submitted to Safety and Fire Prevention 90 days in advance and must meet American National Standards Institute (ANSI) regulations E-1.21. Depending on size, attachments and weight, facility may require a third-party engineer's stamp of approval. The engineer's stamp of approval must include wind load and seismic load. This will be at the exhibitor's expense. Please send to [boothplans@lvcva.com](mailto:boothplans@lvcva.com).
- If an exhibitor has their own ballast (weight), but it is deemed insufficient by the facility, they must procure additional ballast from a local source and/or the show's official service contractor (OSC) at their own expense.

## DEMONSTRATIONS

- When conducting demonstrations or presentations, all activity and viewers must be contained within the booth and all aisles must remain clear. To prevent gatherings in an aisle, demonstrations cannot be conducted on any edge of the booth along an aisle.



## The ARA Show Statement of Integrity

The ARA Show is the largest event for the equipment and event rental industry, and we want to ensure it continues to live up to our member's expectations and our internal standards. At the American Rental Association, integrity in our interactions is the foundation for our mission. In fact, one of our core values is to "represent professionalism and integrity in the equipment rental industry."

Regarding the integrity around the ARA Show, the Exhibitor Advisory Council developed the following ARA Show Statement of Integrity:

With respect to participation in The ARA Show, all exhibitors and exhibitor-appointed contractors will act with integrity and adhere to the highest standards of moral and ethical values throughout the planning and execution of the annual trade show. The rental industry is best served when all exhibitors display their best personal and professional behavior.

1. All exhibitors will be familiar with the Rules and Regulations document and comply to the best of their abilities.
2. All exhibitors will ask the ARA for help if any Rules or Regulations are either unclear or present a compliance concern.
3. All exhibitors understand that decisions are made for the good of the Show and that may not necessarily be the best decision for your particular company.

In the case of rules violations or in practices determined to be unethical and inappropriate within The ARA Show:

- a. ARA has the right to deny entry or remove any exhibitor or exhibit that is determined ineligible, or whose presentation is deemed not in the best interest of the ARA Show or has violated the rules.
- b. ARA will discipline such exhibitors as deemed appropriate.

Some examples, while not exhaustive, where exhibitors would not comply with the spirit of the Statement of Integrity and/or Show rules:

- Going into another booth uninvited to take pictures or video
- Taking customers off the floor, out of the building to have meals or network during show hours
- Hosting events in conflict with scheduled ARA events
- Displaying any equipment outside of the show floor

Failure to comply with the rules and regulations may result in the loss of priority points, the removal of Exhibitor's exhibit and/or its agents or employees from The ARA Show, the exclusion from future trade shows and/or other discipline determined by ARA in its sole discretion.

The Statement of Integrity should be reviewed in conjunction with the Show Rules and Regulations document. Exhibitors should be aware that they have signed a contract stating they have read, understand, and agree to abide by these rules. As stated in the Exhibitor Contract, "We, including our exhibitor-appointed contractors, agree to abide by the Rules and Regulations governing The ARA Show."

The intention of this Statement of Integrity is to help exhibitors understand The ARA Show expectations and ensure consistency in how Show rules and guidelines will be administered. The goal is for all show exhibitors to be treated fairly.

As members of ARA, exhibitors demonstrate unyielding and uncompromised integrity in support of the highest standards of excellence for the Show. As individuals, we all contribute to this standard of excellence to have the best outcome for exhibitors and attendees.